

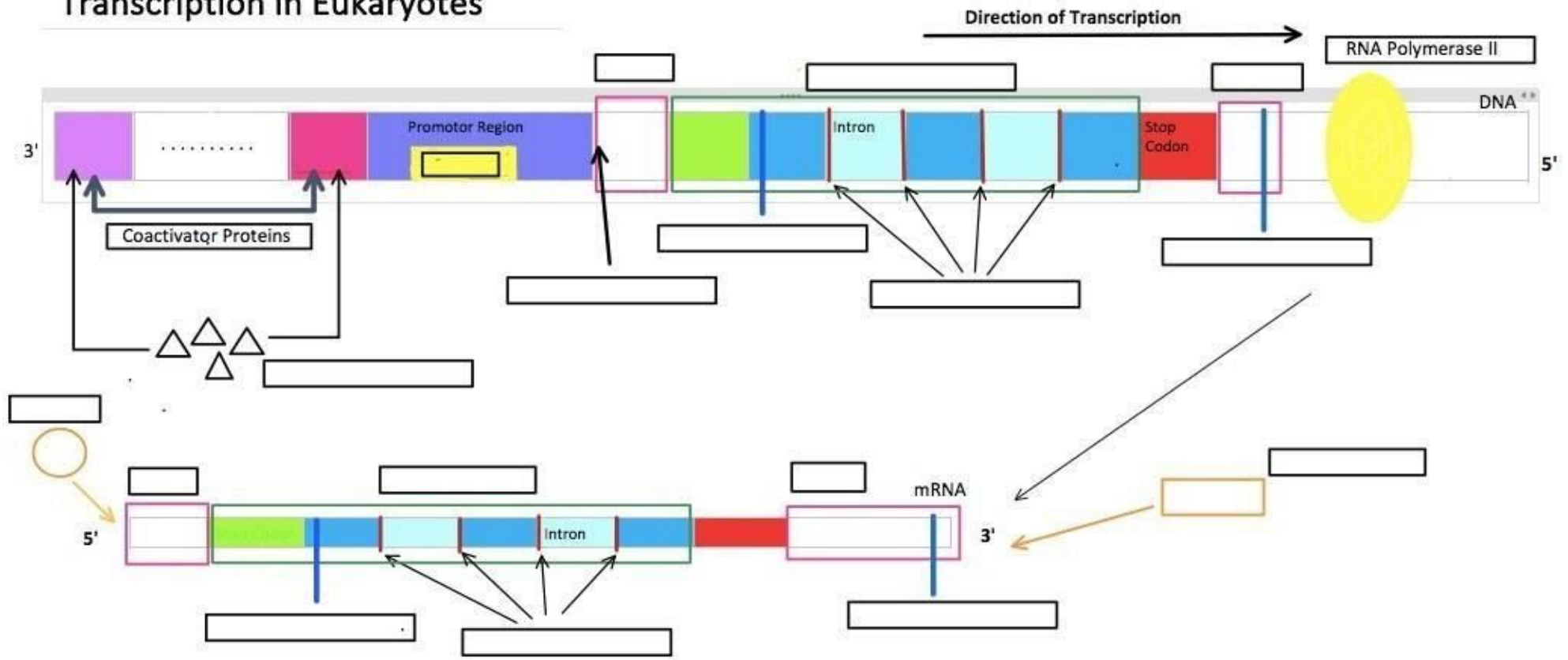

Biology 1002B - WebStraw's Activity Sheet #2

Test your knowledge by filling out this table to the best of your ability. Good luck!
Check out www.webstraw.ca for more resources.

Transcription in Eukaryotes



Answer Key

Study this diagram and reference it when attempting to visualize where each signal/sequence belongs. Once you feel comfortable with it, attempt to draw it on your own.

Transcription in Eukaryotes

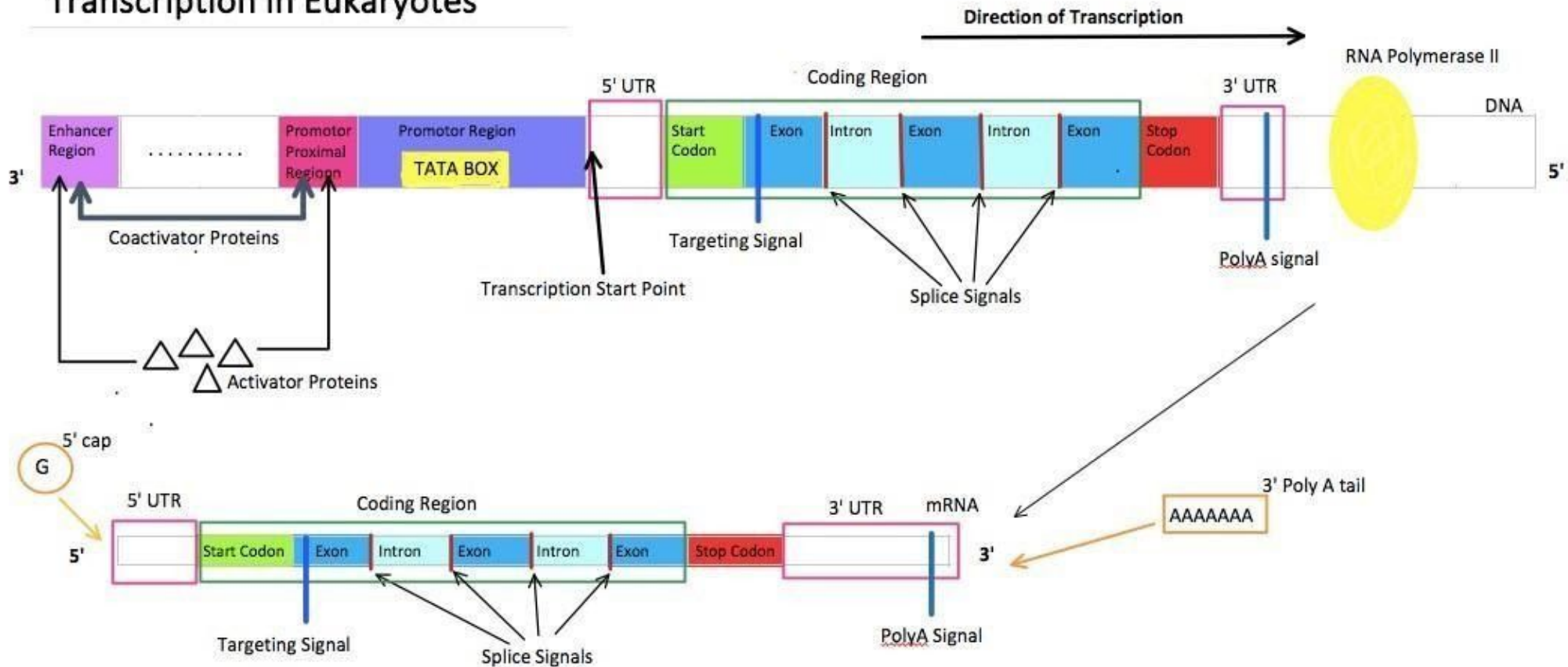

WebStraw would like to thank Hayley Thode for taking full lead on this activity and recognize the contribution of The Bio Team at WebStraw for creating this product to help the students of Bio 1002.